



**ibx100**  
SPRAYER

**IBX100 RCU CONTROL UNIT**

**CE**

**4679000**  
**4679003**

**INSTALLATION**

 = Generic danger

 = Warning

<b>1</b>	<b>Risks and protections before assembly .....</b>	<b>3</b>
<b>2</b>	<b>Intended use .....</b>	<b>3</b>
<b>3</b>	<b>Precautions .....</b>	<b>3</b>
<b>4</b>	<b>Package content .....</b>	<b>3</b>
<b>5</b>	<b>Position on farming machine .....</b>	<b>4</b>
5.1	System recommended composition .....	4
5.2	Control unit fixing .....	7
5.3	Wiring connections .....	8
5.4	IBX100 - MONITOR connection .....	9
<b>6</b>	<b>Wiring connections .....</b>	<b>12</b>
6.1	General precautions for a correct harness position .....	12
6.2	Control unit (ECU) connection (IBX100) .....	12
6.3	Securing the Seletron cables .....	13
6.4	Control unit valve connection - SYSTEM WITH SECTION VALVES .....	15
6.5	Hydraulic valve connection .....	15
6.6	Sensor connection .....	16
6.7	Power supply connection .....	17
<b>7</b>	<b>Maintenance / diagnostics / repairs .....</b>	<b>18</b>
7.1	KEY TO LED STATUS .....	18
7.2	Cleaning rules .....	18
<b>8</b>	<b>Technical data .....</b>	<b>19</b>
	Power supply .....	19
<b>9</b>	<b>Disposal at the end of service .....</b>	<b>19</b>
<b>10</b>	<b>Guarantee terms .....</b>	<b>19</b>
<b>11</b>	<b>Conformity Declaration .....</b>	<b>19</b>

## 1 RISKS AND PROTECTIONS BEFORE ASSEMBLY

All installation works must be done with battery disconnected, using suitable tools and any individual protection equipment deemed necessary.

-  Use **ONLY** clean water for treatment tests and simulations: using chemicals during simulated treatment runs can seriously injure persons in the vicinity.

## 2 INTENDED USE

This device is designed to work on agricultural machinery for spraying and crop spraying applications.

-  The machine is designed and built in compliance with EN ISO 14982 standard (Electromagnetic compatibility - Forestry and farming machines), harmonized with 2004/108/EC Directive.

## 3 PRECAUTIONS

-  • Do not aim water jets at the equipment.  
 • Do not use solvents or fuel to clean the case outer surface.  
 • Do not clean equipment with direct water jets.  
 • Comply with the specified power voltage (12 VDC).  
 • In case of voltaic arc welding, remove connectors from device and disconnect the power cables.  
 • Only use ARAG genuine spare parts and accessories.

## 4 PACKAGE CONTENT



Fig. 1

- 1** Control unit  
**2** Instruction manual (DVD-ROM)  
**3** Connector closing cap



Wiring must be ordered separately (Ref. to ARAG general catalog)

**5 POSITION ON FARMING MACHINE**

**5.1 System recommended composition**

**!** Connect the power cable directly to the battery using the suitable eyelets.  
**WARNING! DO NOT connect to key-operated switch (15/54)**

To connect all parts of the system correctly, make sure to use the proper connection cables specified in tab. 1 on page 5 are correct.  
 Consider all possible variants

- type of system,
- type of Seletron units connected (single, twin or fourfold)
- number of nozzles per mechanical arm (of spraying boom)

**INSTALLATION DIAGRAM  
 VERSION FOR SELETRON AND HYDRAULIC CONTROLS**

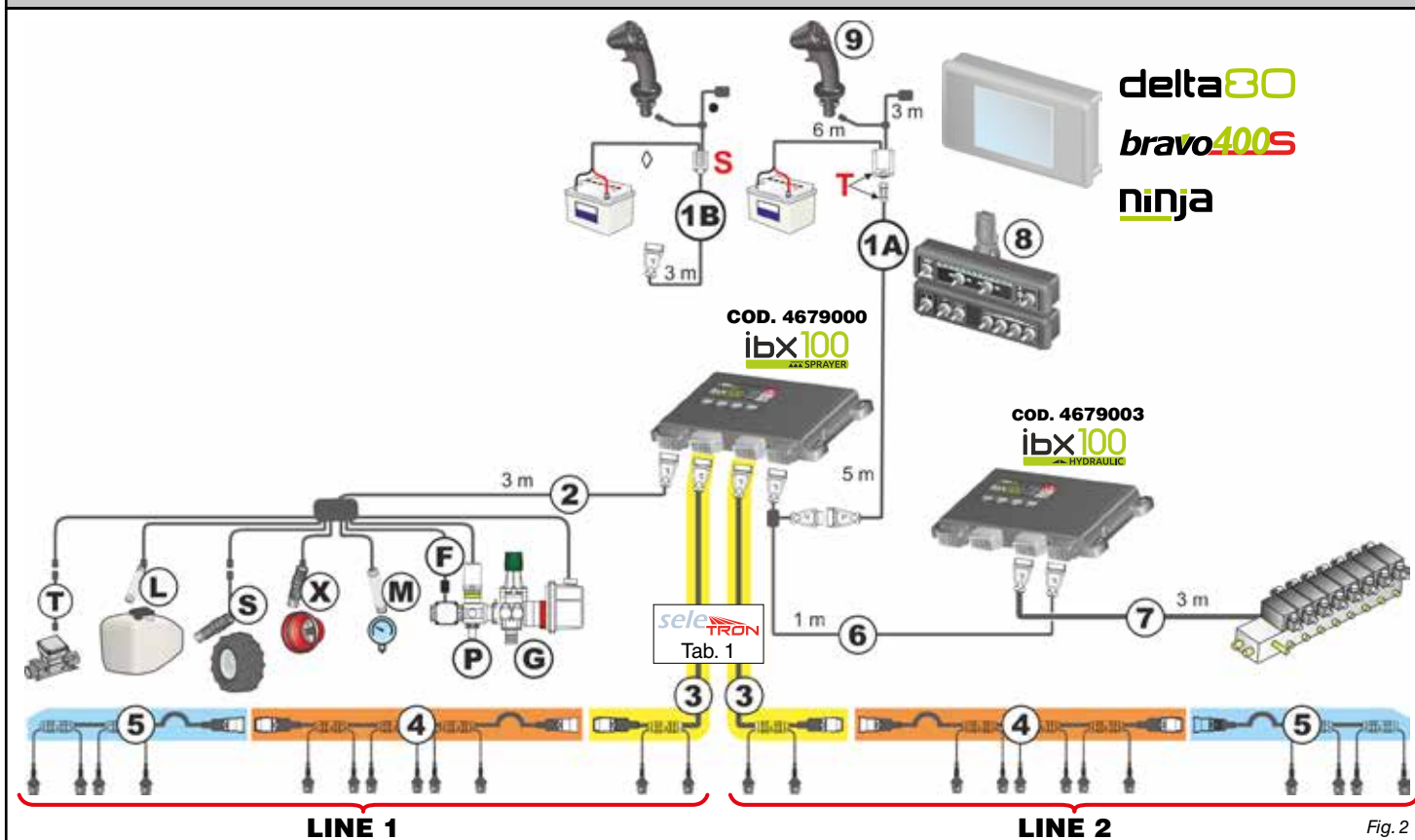

Fig. 2

**Legend of connection cables:**

- 1A** Monitor / IBX100 / battery for **TOWED MACHINE(T)**
- 1B** Monitor / IBX100 / battery for **SELF-PROPELLED MACHINE(S)**
- 2** Sensors / control unit
- 3** Head-end cable
- 4** Extension cable
- 5** Termination cable
- 6** IBX100 Hydraulic
- 7** Hydraulic unit
- 8** Switch box
- 9** Explorer joystick
- S** Speed sensor
- T** Filling flowmeter
- X** RPM sensor
- L** Level sensor
- M** Pressure sensor
- F** Flowmeter
- P** Control valve
- G** Main valve

NUM.	TYPE	COD.		
<b>1A</b>	<b>T</b>	4679000.151		Cable connecting <b>DELTA 80</b> - IBX100 control unit - battery
<b>1B</b>	<b>S</b>	∅ 6m • 6m	4679000.101	
<b>1B</b>	<b>S</b>	∅ 2m • 3m	4679000.102	
<b>1A</b>	<b>T</b>	4679000.153		Cable connecting <b>BRAVO 400S</b> - Control unit IBX100 Sprayer - battery
<b>1B</b>	<b>S</b>	∅ 6m • 6m	4679000.106	
<b>1B</b>	<b>S</b>	∅ 2m • 3m	4679000.107	
<b>1B</b>	<b>S</b>	∅ 3m • 1,5m	4670900.100	Cable connecting <b>NINJA</b> - Control unit IBX100 Sprayer - battery

**!** **WARNING: CABLE CODE 4670900.100 ALLOWS CONNECTING MAXIMUM 24 SINGLE SELETRON UNITS OR 12 TWIN / FOURFOLD SELETRON UNITS**

CONTINUES >>>

Tab. 1 - CONNECTION CABLES

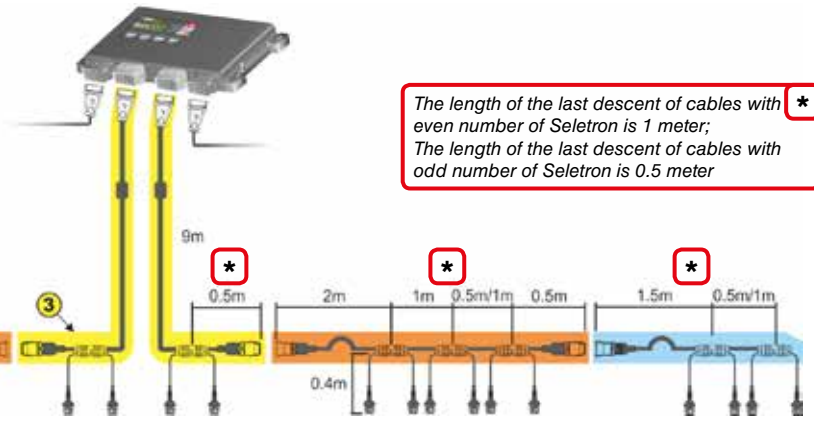

The length of the last descent of cables with even number of Seletron is 1 meter;  
The length of the last descent of cables with odd number of Seletron is 0.5 meter



**CABLES FOR SELETRON - SINGLE  
MAX. BOOM WIDTH 52 m  
CABLES FOR SELETRON -  
TWIN / FOURFOLD  
MAX. BOOM WIDTH 36 M  
50 cm spacing**



**CABLES FOR SELETRON - FOURFOLD  
MAX. BOOM WIDTH 36 M  
50 cm spacing**

The cables for single and twin SELETRON feature 2 outputs per joint.

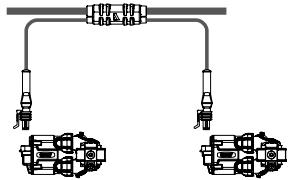

The cables for fourfold SELETRON feature 4 outputs per joint..

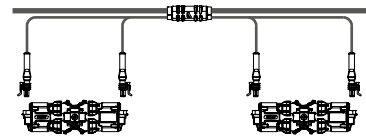

**3 - CENTRAL CABLES**

Code	no. of SELETRON nozzle holders	Cable length (m)
467 491 C020.121	2	2
467 491 C020.120	2	9,5
467 491 C031.121	3	2,5
467 491 C031.120	3	10
467 491 C041.120	4	10,5

**3 - CENTRAL CABLES**

Code	no. of SELETRON nozzle holders	Cable length (m)
467 491 D020.101	2	2
467 491 D020.120	2	9,5
467 491 D031.101	3	2,5
467 491 D031.120	3	10

**4 - PLUS EXTENSION CABLES**

Code	no. of SELETRON nozzle holders	Cable length (m)
467 492 C031.100	3	3
467 492 C041.100	4	3,5
467 492 C051.100	5	4
467 492 C061.100	6	4,5
467 492 C071.100	7	5
467 492 C081.100	8	5,5
467 492 C091.100	9	6
467 492 C101.100	10	6,5
467 492 C111.100	11	7
467 492 C121.100	12	7,5
467 492 C131.100	13	8
467 492 C141.100	14	8,5
467 492 C151.100	15	9
467 492 C161.100	16	9,5
467 492 C171.100	17	10
467 492 C181.100	18	10,5
467 492 C191.100	19	11
467 492 C201.100	20	11,5

Code	no. of SELETRON nozzle holders	Cable length (m)
467 492 D031.100	3	3
467 492 D041.100	4	3,5
467 492 D051.100	5	4
467 492 D061.100	6	4,5
467 492 D071.100	7	5
467 492 D081.100	8	5,5
467 492 D091.100	9	6
467 492 D101.100	10	6,5
467 492 D111.100	11	7
467 492 D121.100	12	7,5
467 492 D131.100	13	8
467 492 D141.100	14	8,5
467 492 D151.100	15	9
467 492 D161.100	16	9,5
467 492 D171.100	17	10
467 492 D181.100	18	10,5
467 492 D191.100	19	11
467 492 D201.100	20	11,5

**5 - PLUS TERMINATION CABLES**

Code	no. of SELETRON nozzle holders	Cable length (m)
467 493 C031.100	3	2
467 493 C041.100	4	2,5
467 493 C051.100	5	3
467 493 C061.100	6	3,5
467 493 C071.100	7	4
467 493 C081.100	8	4,5

Code	no. of SELETRON nozzle holders	Cable length (m)
467 493 D031.100	3	2
467 493 D041.100	4	2,5
467 493 D051.100	5	3
467 493 D061.100	6	3,5
467 493 D071.100	7	4
467 493 D081.100	8	4,5

>>> 5.1 System recommended composition

**!** Connect the power cable directly to the battery using the suitable eyelets.  
**WARNING! DO NOT connect to key-operated switch (15/54)**  
 To connect all parts of the system correctly, make sure to use the proper connection cables.  
 Consider any variants depending on system type.

**INSTALLATION DIAGRAM  
 SECTION VALVE VERSION AND HYDRAULIC CONTROLS**

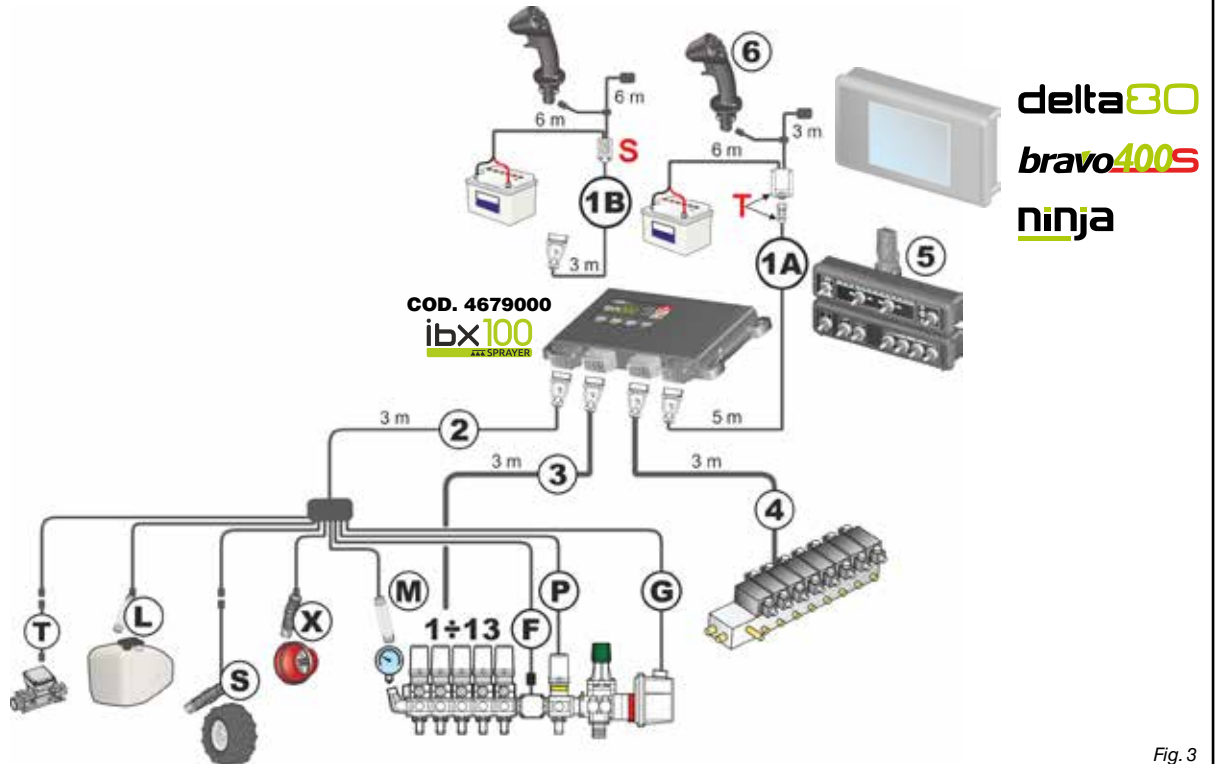

Fig. 3

**Legend of connection cables:**

- 1A** Monitor / IBX100 / battery for **TOWED MACHINE (T)**
- 1B** Monitor / IBX100 / battery for **SELF-PROPELLED MACHINE(S)**
- 2** Sensors / control unit (G + P)
- 3** Control unit (section valves)
- 4** Hydraulic unit
- 5** Switch box
- 6** Joystick Explorer
- S** Speed sensor
- T** Filling flowmeter
- X** RPM sensor
- L** Level sensor
- M** Pressure sensor
- F** Flowmeter
- P** Control valve
- G** Main valve

NUM.	TYPE	COD.	
<b>1A</b>	<b>T</b>	<b>4679000.150</b>	Cable connecting <b>DELTA 80</b> -
<b>1B</b>	<b>S</b>	<b>4679000.103</b>	Control unit IBX100 Sprayer - battery
<b>1A</b>	<b>T</b>	<b>4679000.152</b>	Cable connecting <b>BRAVO 400S</b> -
<b>1B</b>	<b>S</b>	<b>4679000.105</b>	Control unit IBX100 Sprayer - battery
<b>1B</b>	<b>S</b>	<b>4670900.100</b>	Cable connecting <b>NINJA</b> -
			Control unit IBX100 Sprayer - battery

5.2 Control unit fixing

Secure the control units on the back of the machine, close to the control unit and the hydraulic unit.

Consider all necessary connections of the device (par. 5.3), the cable length, and make sure there is enough space for connectors and cables.

For any reference to the system configuration read par. 5.1.

Respect the mounting direction of the control units, as specified in Fig. 4 (connectors shall be facing down)

Fasten the IBX100 using 4 bolts installed in the relevant slots (A, Fig. 4).



Any other positioning is not allowed

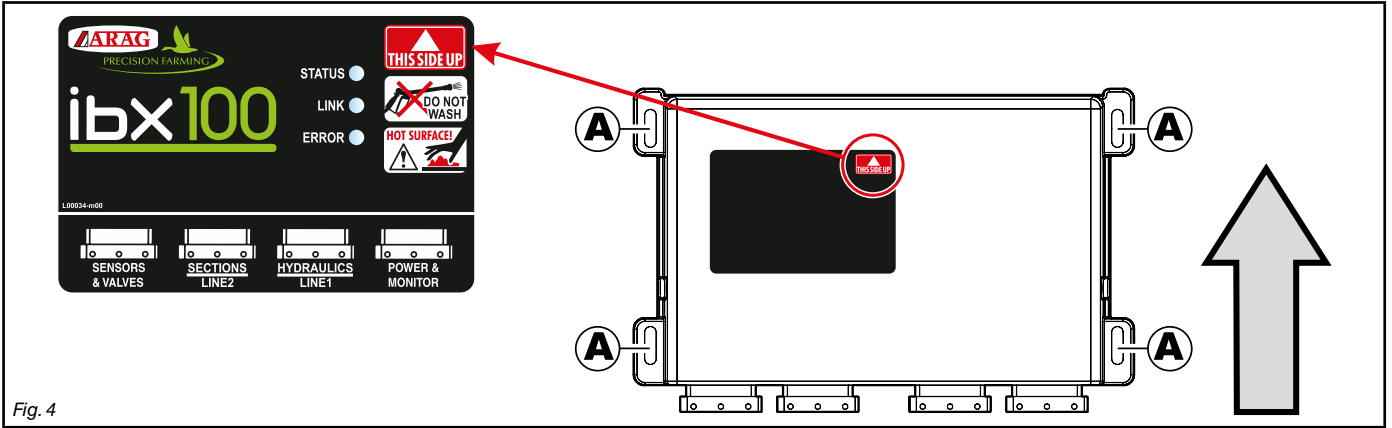

Fig. 4

OVERALL DIMENSIONS

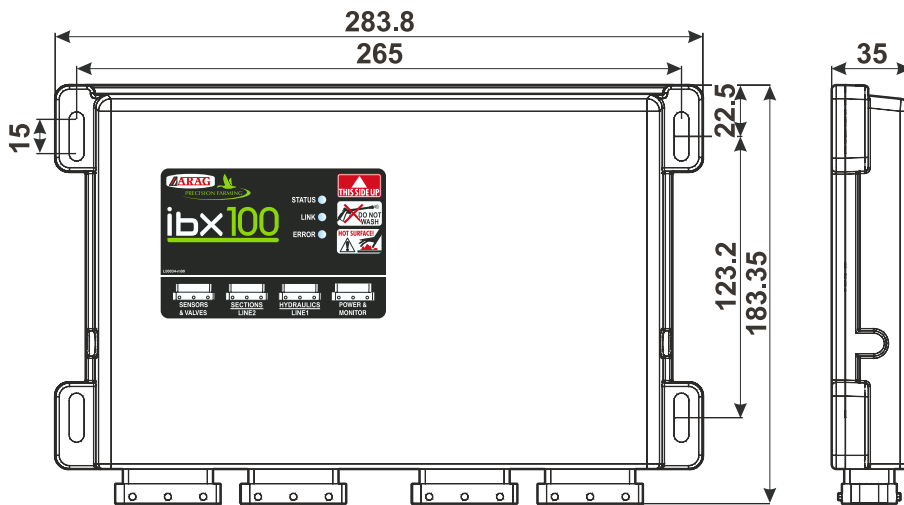

Fig. 5

Unit of measure: mm

5.3 Wiring connections

**IBX100 SPRAYER**

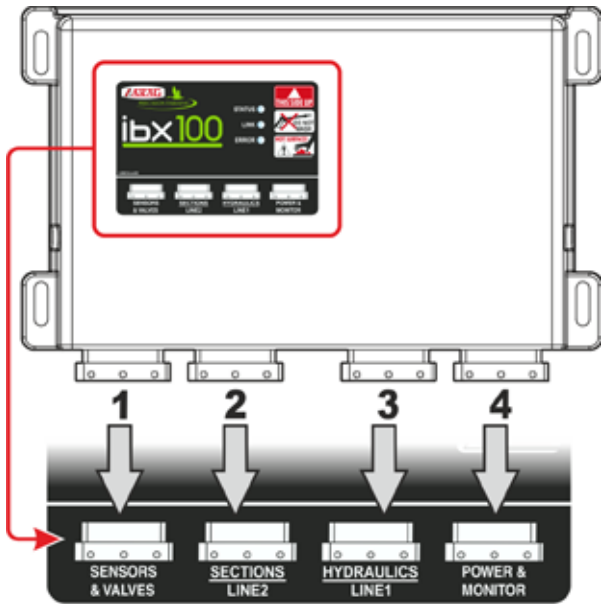

Fig. 6

NUM	CONNECTION POINTS	
1	Control unit (G + P) + Sensors	
2	Control unit (section valves)	<b>SYSTEM WITH SECTION VALVES</b>
3	Hydraulic unit	
2	Seletron - Line 2	<b>SYSTEM WITH SELETRON</b>
3	Seletron - Line 1	
4	Monitor + power supply + IBX100 Hydraulic (hydraulic controls)	

**IBX100 HYDRAULIC**

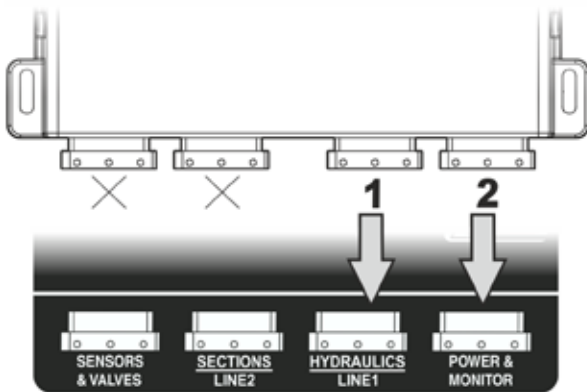

Fig. 7

NUM	CONNECTION POINTS
1	Hydraulic unit
2	IBX100 Sprayer (water controls)



5.4 IBX100 - MONITOR connection

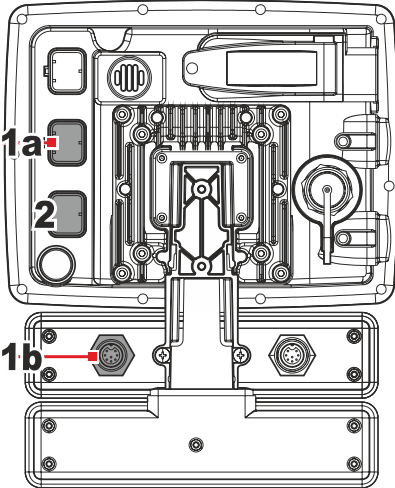

Fig. 8



**HARNESS CONNECTION FOR SPRAYER MODE**

DELTA 80 WITH SWITCH BOX	
NUM	CONNECTION
1a + 1b	Monitor / Switch box* / Auxiliary functions*
2	Monitor / IBX100 / Power supply

DELTA 80 WITH JOYSTICK	
NUM	COLLEGAMENTO
1a	Monitor / Auxiliary functions
2	Monitor / IBX100 / Power supply



\* There are different cables available for switch box connection (ARAG general catalog). Alternatively, connect the joystick (Fig. 11).

The hydraulic or section valve controls are managed via switch box; alternatively, connect the joystick.  
**TO ENSURE THE SYSTEM CORRECT OPERATION CONNECT AT LEAST ONE OF THE TWO DEVICES TO THE IBX100.**

**SWITCH BOX CONNECTION**

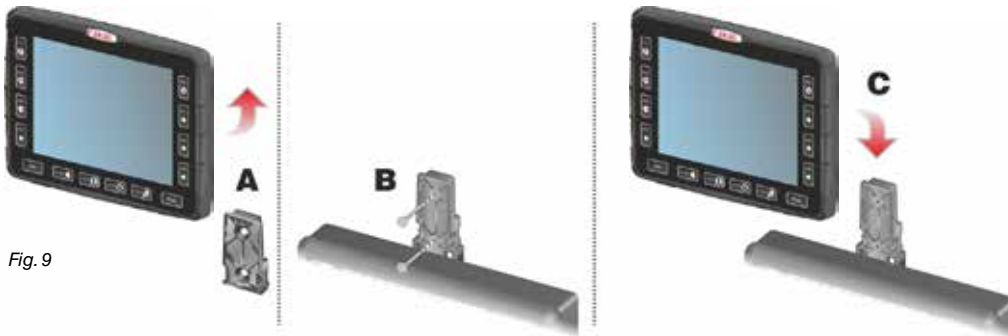

Fig. 9

**• Fixing**

The bracket must be slid out of the monitor seat (A, Fig. 9) and fixed using the supplied screws (B). Make sure the bracket is securely mounted, fit the monitor on it, and push it until it locks in place (C).

**• Connection**

Fasten connectors (see connection points under par. 5.3), ensure they are correctly in place and turn the ring nut clockwise until blocking them.

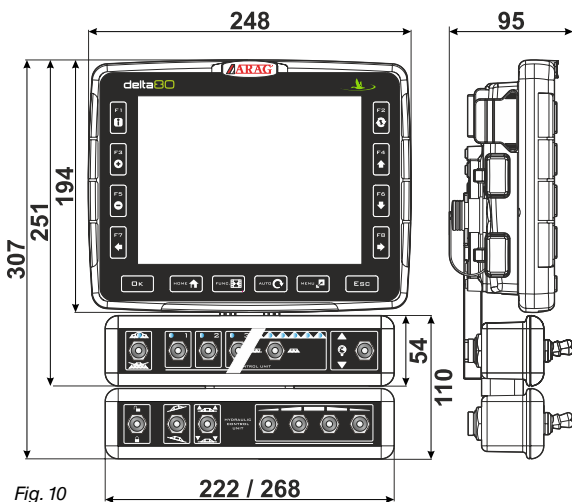
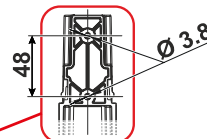
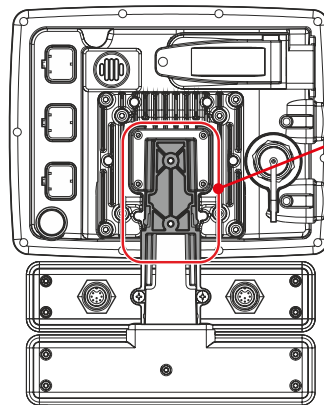

Fig. 10



**WARNING:** the switch box must be fixed only by means of the supplied bracket, and using suitable screws. NO OTHER TYPE OF FASTENING IS ALLOWED. ARAG is not liable for damages to the equipment, persons or animals caused by failure to observe the above instructions.

**JOYSTICK CONNECTION**



Fig. 11

Connect the joystick to the relevant connector on the power supply harness.

>>> 5.4 IBX100 - MONITOR connection

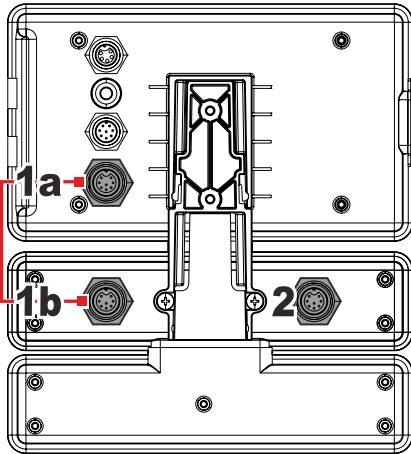

Fig. 12



**HARNESS CONNECTION FOR SPRAYER MODE**

DELTA 80 WITH SWITCH BOX	
NUM	CONNECTION
1a + 1b	Monitor / Switch box*
2	IBX100 / Power supply

BRAVO 400S WITH JOYSTICK	
NUM	CONNECTION
1a	Monitor / IBX100 / Power supply

\* There are different cables available for switch box connection (ARAG general catalog). Alternatively, connect the joystick (Fig. 15).

The hydraulic or section valve controls are managed via switch box; alternatively, connect the joystick  
**TO ENSURE THE SYSTEM CORRECT OPERATION CONNECT AT LEAST ONE OF THE TWO DEVICES TO THE IBX100 .**

**SWITCH BOX CONNECTION**

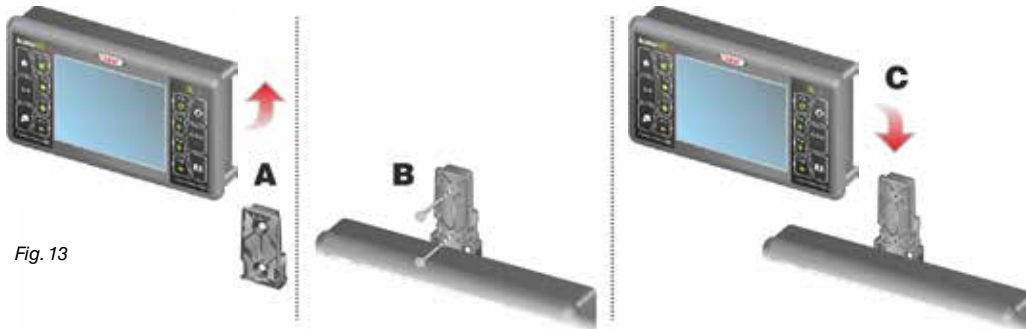

Fig. 13

**• Fixing**  
 The bracket must be slid out of the monitor seat (A, Fig. 13) and fixed using the supplied screws (B).  
 Make sure the bracket is securely mounted, fit the monitor on it, and push it until it locks in place (C).

**• Connection**  
 Fasten connectors (see connection points under par. 5.3), ensure they are correctly in place and turn the ring nut clockwise until blocking them.

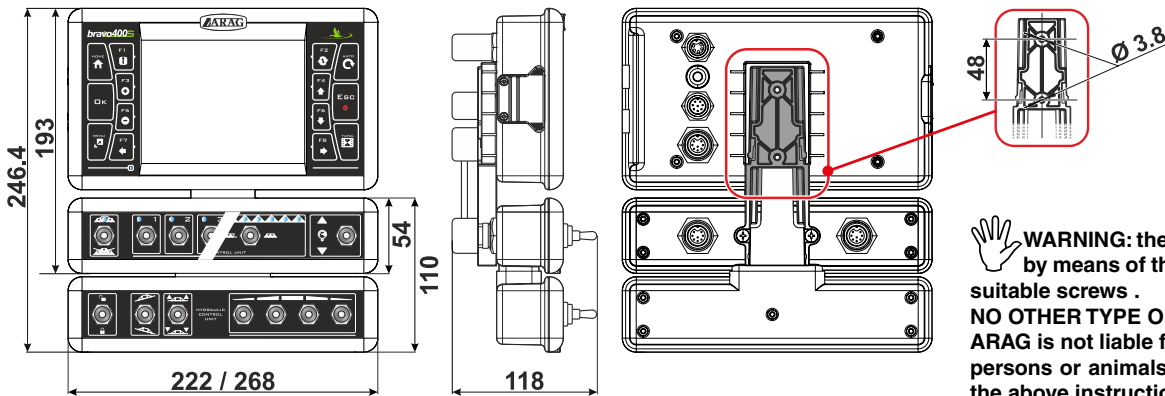

Fig. 14

**WARNING:** the switch box must be fixed only by means of the supplied bracket, and using suitable screws .  
**NO OTHER TYPE OF FASTENING IS ALLOWED.**  
 ARAG is not liable for damages to the equipment, persons or animals caused by failure to observe the above instructions.

**JOYSTICK CONNECTION**



Fig. 15

Connect the joystick to the relevant connector on the power supply harness.

>>> 5.4 IBX100 - MONITOR connection

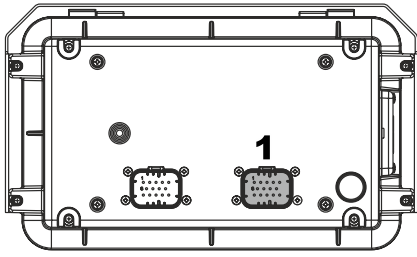

**HARNESS CONNECTION  
FOR SPRAYER MODE**

NUM	CONNECTION
1	Monitor / Auxiliary functions / IBX100 / Power supply

Fig. 16

**COLLEGAMENTO JOYSTICK**



Fig. 17

**6 WIRING CONNECTIONS**



- Use only the cables provided with the ARAG computers.
- Take care not to break, pull, tear or cut the cables.
- Use of unsuitable cables not provided by ARAG automatically voids the warranty.
- ARAG is not liable for damages to the equipment, persons or animals caused by failure to observe the above instructions.

**6.1 General precautions for a correct harness position**

- **Securing the cables:**
  - secure the harness so that it does not interfere with moving parts;
  - route the harnesses so that they cannot be damaged or broken by machine movements or twisting.
- **Routing the cables to protect against water infiltrations:**
  - the cable branches must ALWAYS be face down (Fig. 18).

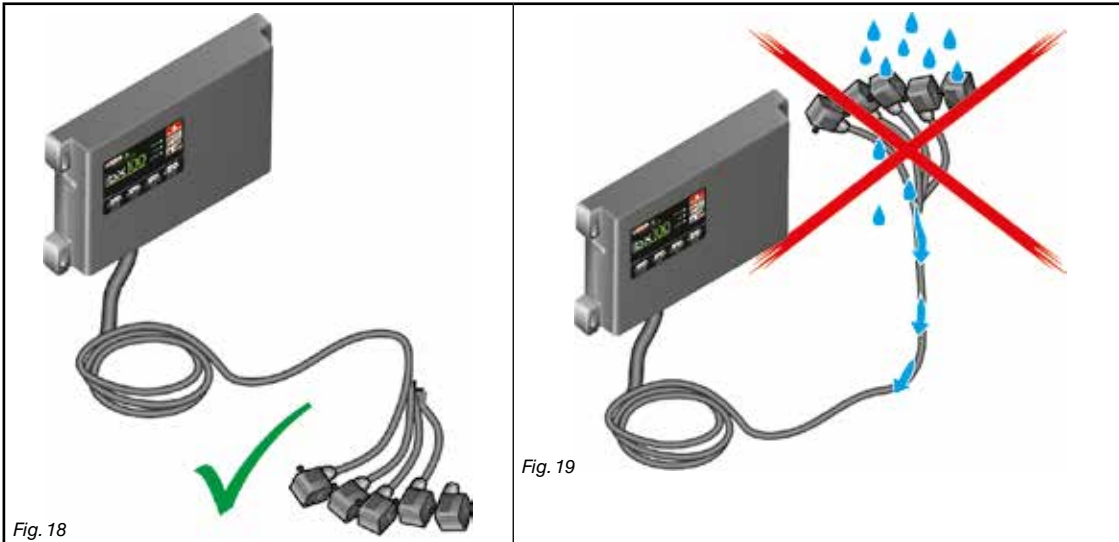

- **Fitting the cables to the connection points:**
    - do not force the connectors by pushing too hard or bending them: the contacts may be damaged and compromise the system correct operation.
- Use ONLY the cables and accessories indicated in the catalog, having technical features suitable for the use to be made of them.**

**6.2 Control unit (ECU) connection (IBX100)**

Connect wiring harnesses as indicated under par. 5.3; each of them must be connected to the corresponding socket on control unit. Close the unused connectors with the relevant caps provided in the package.



**If they prove hard to insert, do not force them, but check the shown position.**

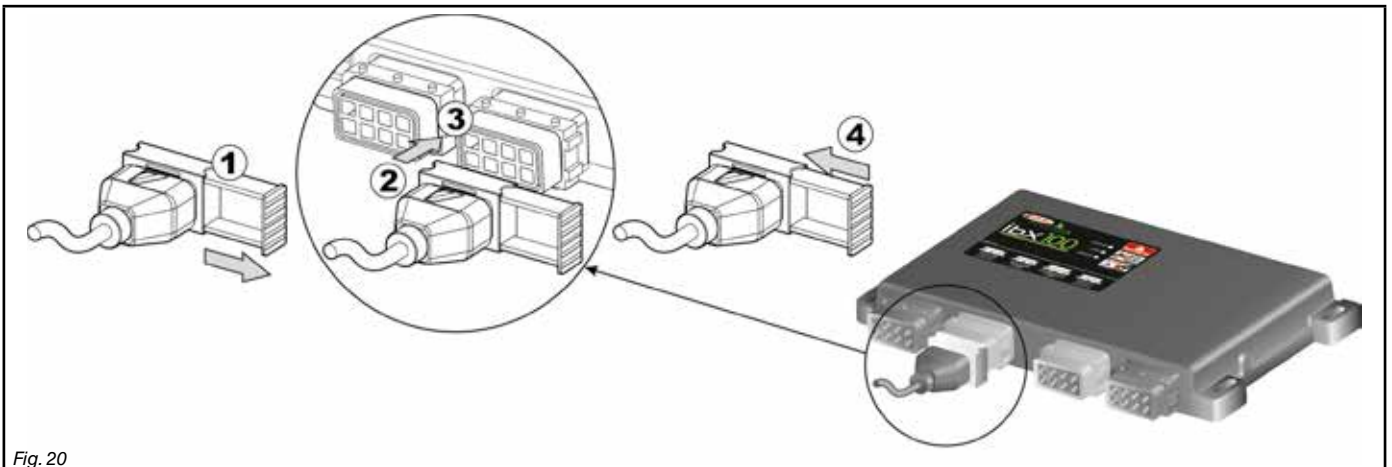

**Some connectors are supplied with separate slide. Manually fit the slide in the most convenient position allowing easy insertion and removal of the connector.**

- Open connector slide (1, Fig. 20).
- Position connector (2) and insert it inside socket (3), then press: **during this operation, take special care not to bend electric contacts.**
- Close slide (4) until it locks in place.

6.3 Securing the Seletron cables

**WARNING: DO NOT CONNECT THE CONNECTORS TO THE SELETRON NOZZLE HOLDERS. THE SELETRON ELECTRIC CONNECTORS MUST BE CONNECTED AT A LATER TIME, DURING THE PAIRING PROCEDURE (ref. "Seletron connection" - software use manual).**

Route the cable following these rules:

**1** The Seletron units are connected to the IBX100 (Fig. 21) via two main wiring harnesses (**1** and **2**) each made up of three types of cables: head-end cable (**3**), extension cable (**4**) and termination cable (**5**); the termination cable is indispensable in order to close circuit. **The system will not operate without a termination cable.**

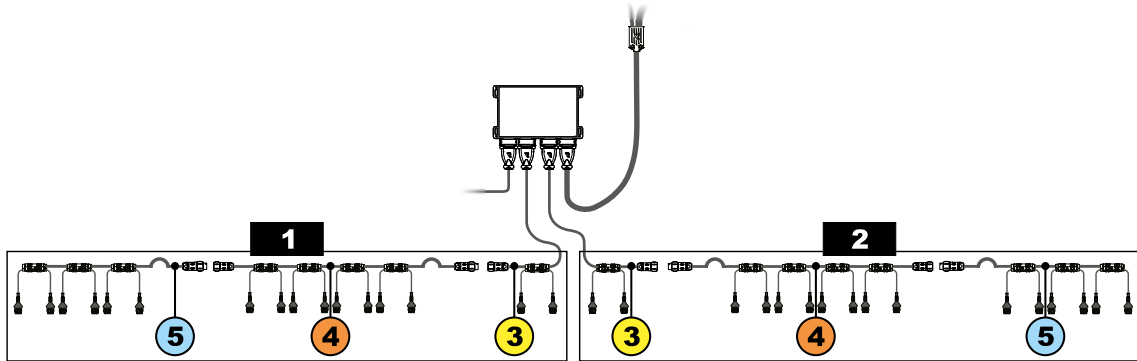

Fig. 21

Consider all necessary connections of the Seletron system, the cable length, and make sure there is enough space for connectors and cables. Secure the cables with ties to protect them from damage.

**Thanks to the modular concept of the system, additional EXTENSION cables can be added to the circuit to connect additional nozzle holders and obtain the desired boom length. To ensure proper operation of the system, observe the wiring diagram and use ONLY dedicated cables for the type of Seletron installed (Tab. 1 - CONNECTION CABLES on page 5).**

**WARNING: THE CABLES DESIGNED FOR CONNECTING TWIN SELETRON UNITS ON BOOMS UP TO 24 M LONG SHOULD NEVER BE USED ON LONGER BOOMS.**

**2** IBX100 main control valve, flowmeter and pressure sensor must be installed in the front section of the machine; if needed, ONLY the sensors may be moved to a different position and connected using the extensions listed in the catalogue. **Never use an extension for any other components unless you have so agreed with the ARAG Assistance Center.**

**3** Choose and install the cables so that they retain some freedom of movement at boom joints.

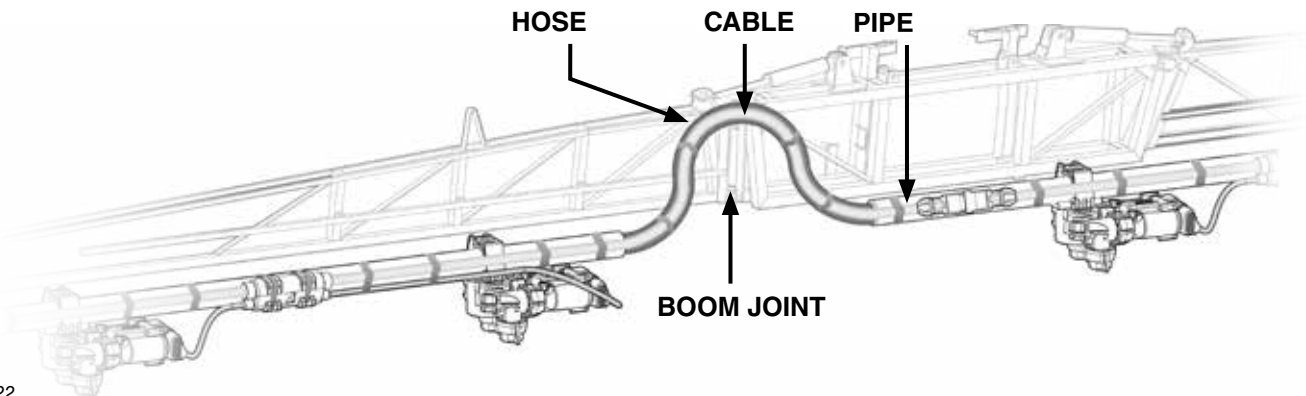

Fig. 22

**4** ALWAYS secure the main cable connections (**3**, **4** and **5**) to a stationary section of the boom; the head-end cable is longer than the termination to facilitate this.

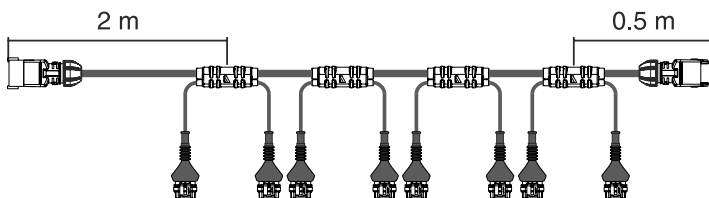

Fig. 23

**5** Account for any possible boom movement when positioning and fixing the cables.

**6** Respect the position of the connectors and do not force their insertion: the position is correct when guides **A** (Fig. 17) engage in the relevant slots

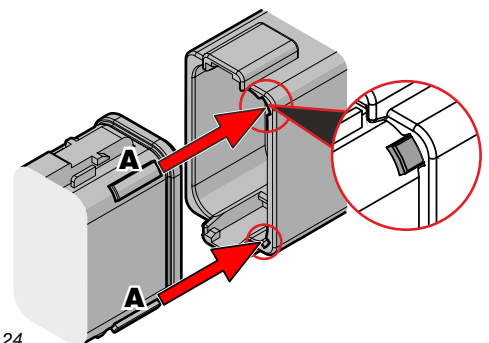

Fig. 24

**7** Carefully check that no connections or branches are positioned near moving parts and high enough to clear possible obstacles on the ground. Ensure that the Seletron nozzle holders do not become jammed with one another or touch any cables or delicate system areas when the boom is closed or folded away.

8 If space is limited and you need to bend a cable, be sure not to bend it too tight or it may get damaged.

**OK**

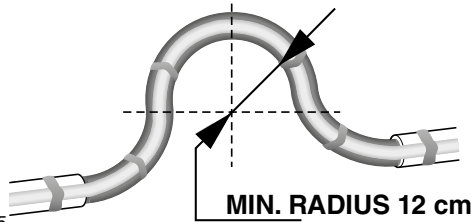
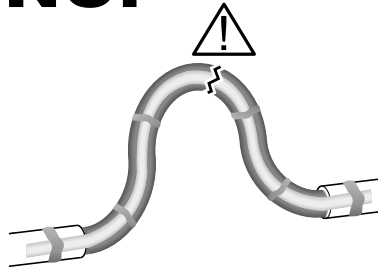

Fig. 25

**NO!**



9 Position the cable so that branches A are equally spaced from Seletron connectors B.

**NO!**

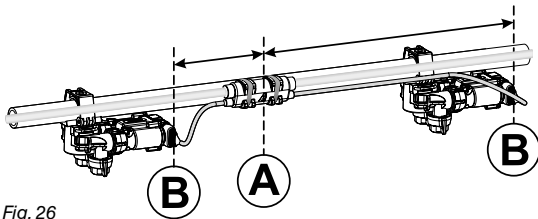
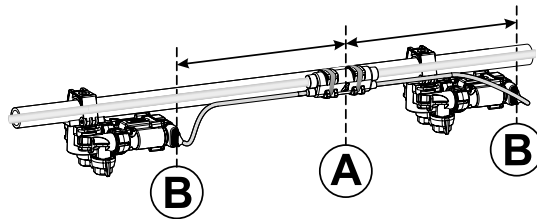

Fig. 26

**OK**



10 Secure the branches to the boom threading the ties through the suitable recesses.

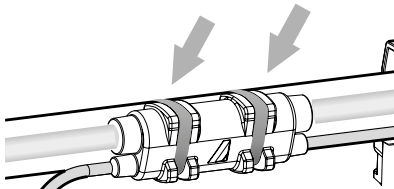

Fig. 27

11 When installing a twin or fourfold nozzle holder, make sure that all connectors are facing the same direction, or the computer might select the wrong nozzle.

**OK**

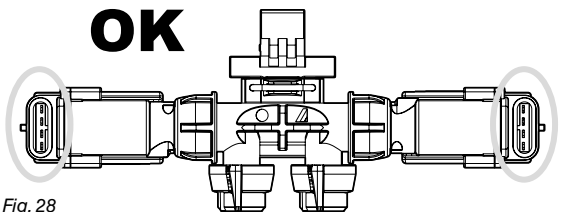
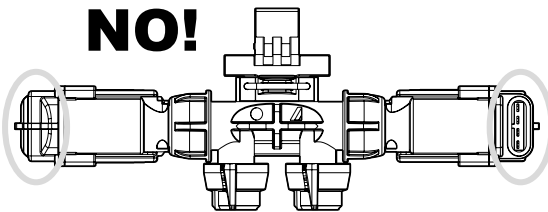

Fig. 28

**NO!**



For special needs it is possible to install two nozzles on boom ends that can work instead of the standard outer nozzles.

**Any Seletron connectors left unused must be closed using the suitable plugs (code ECS0075). The plugs must be ordered separately.** When the connectors are plugged off, the Seletron is sealed. To avoid damaging the internal components, make sure that when using or cleaning the system the plugs and the connectors are not bare or inserted incorrectly.



**OK**



**NO!**

**WARNING!**  
**DO NOT CONNECT THE SELETRON UNITS.**  
**THE SELETRON ELECTRIC CONNECTORS MUST BE CONNECTED AT A LATER TIME, DURING THE PAIRING PROCEDURE (ref. "Seletron connection" - software use manual).**

Fig. 29



**WARNING: TO AVOID DAMAGING ONE OR MORE DEVICES, MAKE SURE THAT NONE OF THE PARTS OF EACH SINGLE SELETRON (BODY, HARNESSSES, ETC.) COME INTO CONTACT WITH MOVING PARTS AT ANY TIME WHEN THE SYSTEM IS IN USE (INSTALLATION, COMMISSIONING, USE AND SHUTDOWN OF THE FARMING MACHINE).**

**ARAG will not be held responsible for any damage to the system, people, animals or objects caused by failure to follow the guidelines outlined above.**



6.4 Control unit valve connection - SYSTEM WITH SECTION VALVES

- The system works only if made up with 3-wire type valves.
- The computer only works if connected to the 3-wire type valves.
- Use ARAG valves: use of unsuitable valves not provided by ARAG automatically voids the warranty. ARAG is not liable for damage to the equipment, persons or animals caused by failure to observe the above instructions.
- All valve connectors must be provided with seals before being connected (Fig. 31).
- Make sure the seals are correctly fitted to avoid water infiltration when using the control unit.

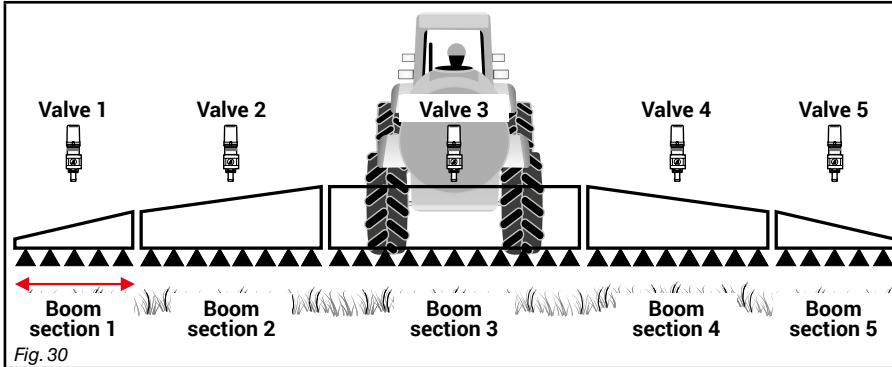

Connector 1 shall control the valve which in turn is connected to the boom section 1, and so on with the other valves. Connect "connector 1" to "valve 1", and then the other connectors with increasing numbers from left to right the boom section 1 is the furthest from the machine on the left, looking at the machine from the rear side (Fig. 30).

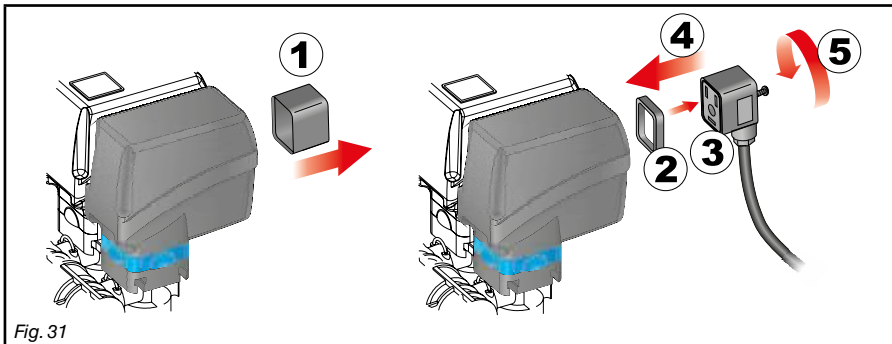

Fix the connectors to the relevant valves according to the initials indicated in your assembly general diagram (par. 5.1 System recommended composition)

- Remove the protection cap (1, Fig. 31) from the electric valve.
- Place the seal (2) onto the connector (3), and push the connector fully on (4): be careful not to bend the contacts upon insertion on the valve.
- Tighten the screw (5) fully home.

6.5 Hydraulic valve connection

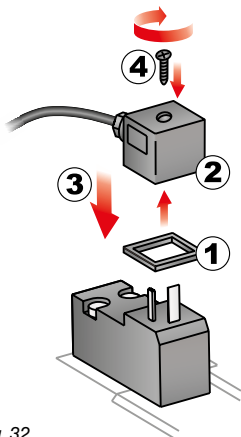











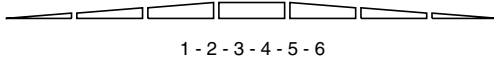

The system can control up to 9 hydraulic functions through double-acting valves.

Fix the connectors to the relevant valves according to the initials indicated in your assembly general diagram (par. 5.1).

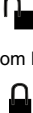
- Position seal (1) onto connector (2), then connect the latter pressing it fully home (3): **during this operation, take special care not to bend valve electric contacts.**
- Insert screw inside connector, and screw it (4) until it is tightened.

The function of each switch on the hydraulic function control panel is described below.

- Connect the connector marked with "DD" to the pilot valve, and then the other connectors, as specified on the table:

CONTROL	MOVEMENT	CONNECTOR
Section movement  1 - 2 - 3 - 4 - 5 - 6	Opening 	1 ÷ 6 A
	Closing 	1 ÷ 6 C
Boom height 	Opening 	AA
	Closing 	AC
Boom lock 	Opening 	BA
	Closing 	BC
Boom leveling 	Opening 	CA
	Closing 	CC

6.6 Sensor connection

Fix the connectors to the relevant functions according to the initials indicated in your assembly general diagram (par. 5.1).

**Harness cables are marked with a symbol denoting their functions: please see the table for correct harness connection.**



**Use ARAG sensors: use of unsuitable sensors not provided by ARAG automatically voids the warranty. ARAG is not liable for damage to the equipment, persons or animals caused by failure to observe the above instructions.**

ITEM	CONNECTION
<b>F</b>	Flowmeter
<b>L</b>	Level sensor
<b>M</b>	Pressure sensor
<b>S</b>	Speed sensor
<b>T</b>	Filling flowmeter
<b>X</b>	RPM sensor

- The products are supplied with the sensor installation instructions.

The following speed sensors can also be used as RPM sensors:

- inductive speed sensor (**code 467100.086**);
- magnetic speed sensor (**code 467100.100**).

- Connection of:

- flowmeter;
- pressure sensor;
- level sensor
- filling flowmeter;
- RPM sensor.

All ARAG sensors use the same type of connector. Connect the sensor connector to the relevant harness; make sure it is correctly fitted and push it until locking it.



Fig. 33



Fig. 34



6.7 Power supply connection

**WARNING:**  
To avoid short circuits, do not connect the power cables to battery before the installation is completed.  
Before powering up the IBX100 make sure the tractor battery voltage is as specified (12 VDC).

**WARNING!** DO NOT connect to key-operated switch (15/54).

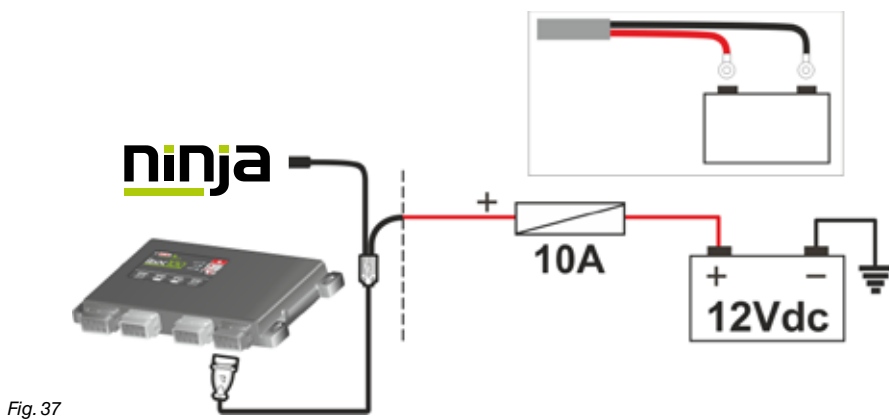
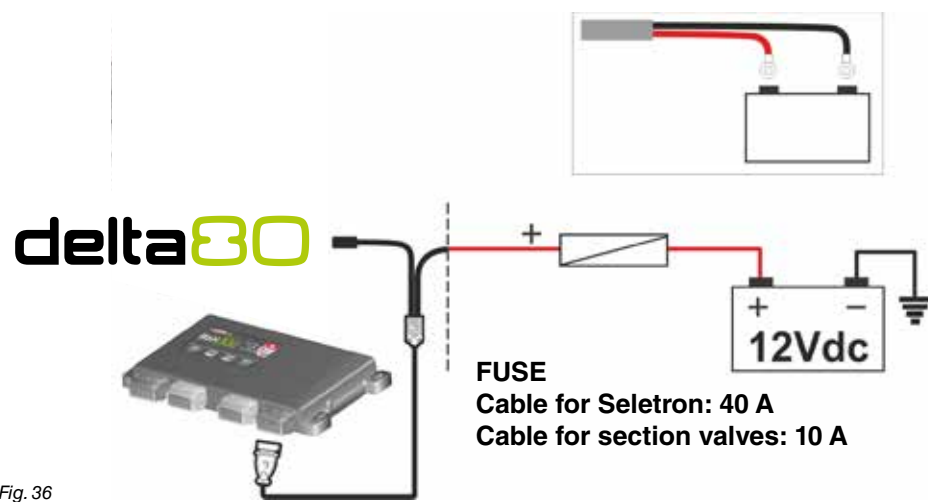
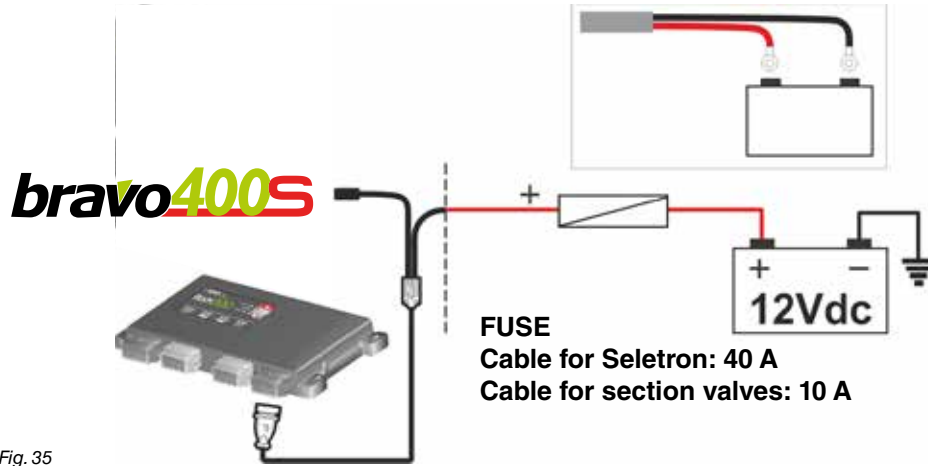

The power source must be connected as indicated below:

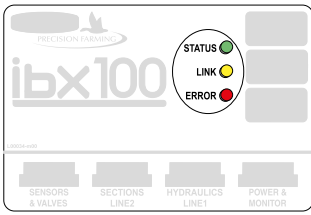

**7 MAINTENANCE / DIAGNOSTICS / REPAIRS**

**7.1 KEY TO LED STATUS**



COLORE	
STATUS 	verde
LINK 	giallo
ERROR 	rosso

- **consistent flashing** = constant flashing
- **periodical flashing** = set of several flashes separated by a pause

**Switch on** Upon start, the control unit switches the LEDs on in the following sequence:  
**1 green LED - 2 yellow LED - 3 red LED**  
 Sequence overall duration: 2 seconds.

**STATUS **

- **off**: unit not powered
- **steady on**: control unit powered, software not present or serious error
- **consistent flashing**: control unit waiting to receive commands from monitor
- **periodical flashing**: control unit operating

**LINK **

- **steady on**: CAN-Bus communication operating properly
- **1 periodical flash**: communication fault with monitor
- **2 periodical flashes**: communication fault with BUS 1 (LINE 1)
- **3 periodical flashes**: communication fault with BUS 2 (LINE 2)

**ERROR **

- **off**: no error
- **1 periodical flash**: high temperature
- **2 periodical flashes**: power voltage out of range
- **3 periodical flashes**: short-circuit or high power input on BUS 1 (LINE 1)
- **4 periodical flashes**: short-circuit or high power input on BUS 2 (LINE 2)
- **5 periodical flashes**: short-circuit or high power input on hydraulic circuit
- **6 periodical flashes**: short-circuit or high power input on control valves
- **7 periodical flashes**: short-circuit or high power input on section valves
- **8 periodical flashes**: analog sensor connection fault

**7.2 Cleaning rules**

- Clean only with a soft wet cloth.
- **DO NOT** use aggressive detergents or products.
- **DO NOT** aim water jets directly at the control unit cleaning .

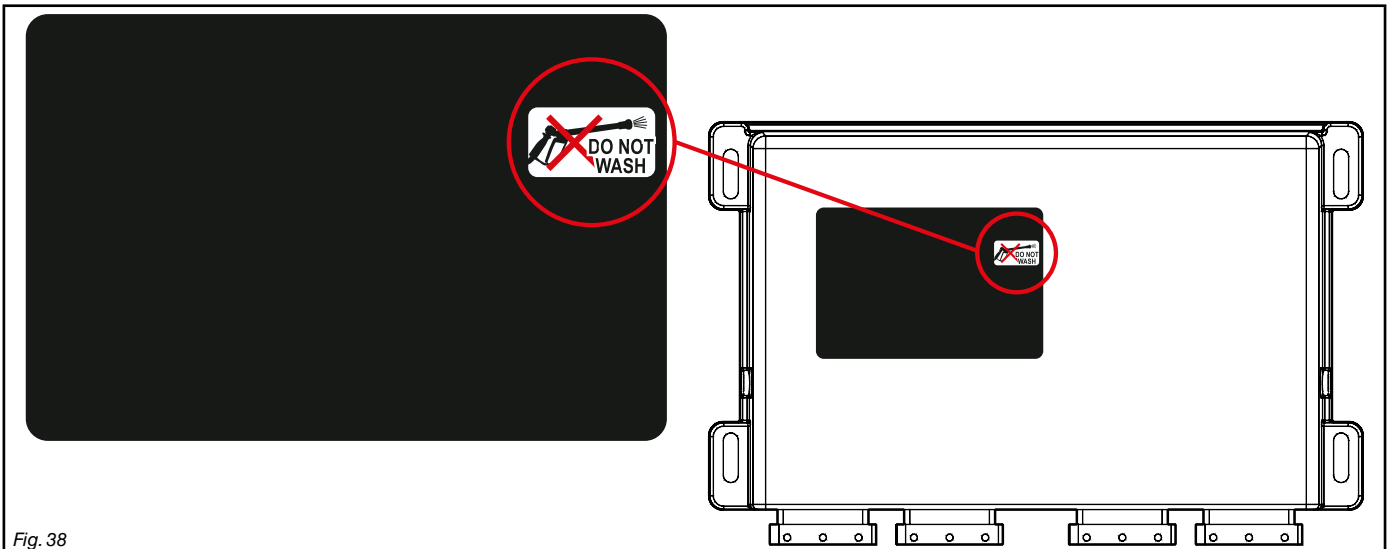

Fig. 38

## 8 TECHNICAL DATA

DESCRIPTION	IBX100
Power supply	9 ÷ 16 Vdc
Working Temperature	-40 °C ÷ +60 °C -40 °F ÷ +140 °F
Storage temperature	-40 °C ÷ +85 °C -40 °F ÷ +185 °F
Weight (without cables)	1213 g
Digital inputs	For sensors Open collector: Max. frequency 2000 Hz
Analogue inputs	4-20 mA
Digital outputs (valvole)	High active (max 200 mA)
Hydraulic valve power outputs	High active (max 2,5 A)
Seletron line power outputs	High active (max 15 A per line)
Protection against polarity inversion	•
Protection against short-circuit	•
Protection class	IP65

## 9 DISPOSAL AT THE END OF SERVICE

Dispose of the system in compliance with the established legislation in the country of use.

## 10 GUARANTEE TERMS

1. ARAG s.r.l. guarantees this apparatus for a period of 360 days (1 year) from the date of sale to the client user (date of the goods delivery note).  
The components of the apparatus, that in the unappealable opinion of ARAG are faulty due to an original defect in the material or production process, will be repaired or replaced free of charge at the nearest Assistance Center operating at the moment the request for intervention is made. The following costs are excluded:
  - disassembly and reassembly of the apparatus from the original system;
  - transport of the apparatus to the Assistance Center.
2. The following are not covered by the guarantee:
  - damage caused by transport (scratches, dents and similar);
  - damage due to incorrect installation or to faults originating from insufficient or inadequate characteristics of the electrical system, or to alterations resulting from environmental, climatic or other conditions;
  - damage due to the use of unsuitable chemical products, for spraying, watering, weedkilling or any other crop treatment, that may damage the apparatus;
  - malfunctioning caused by negligence, mishandling, lack of know how, repairs or modifications carried out by unauthorized personnel;
  - incorrect installation and regulation;
  - damage or malfunction caused by the lack of ordinary maintenance, such as cleaning of filters, nozzles, etc.;
  - anything that can be considered to be normal wear and tear.
3. Repairing the apparatus will be carried out within time limits compatible with the organizational needs of the Assistance Center. No guarantee conditions will be recognized for those units or components that have not been previously washed and cleaned to remove residue of the products used;
4. Repairs carried out under guarantee are guaranteed for one year (360 days) from the replacement or repair date.
5. ARAG will not recognize any further expressed or intended guarantees, apart from those listed here.  
No representative or retailer is authorized to take on any other responsibility relative to ARAG products.  
The period of the guarantees recognized by law, including the commercial guarantees and allowances for special purposes are limited, in length of time, to the validities given here.  
In no case will ARAG recognize loss of profits, either direct, indirect, special or subsequent to any damage.
6. The parts replaced under guarantee remain the property of ARAG.
7. All safety information present in the sales documents regarding limits in use, performance and product characteristics must be transferred to the end user as a responsibility of the purchaser.
8. Any controversy must be presented to the Reggio Emilia Law Court.

## 11 CONFORMITY DECLARATION

The declaration of conformity is available at [www.aragnet.com](http://www.aragnet.com), in the relevant section.

---

*Only use original ARAG accessories and spare parts, to maintain safety conditions foreseen by the constructor. Always refer to the ARAG spare parts catalogue.*

D20353\_GB:m01 11/2019



42048 RUBIERA (Reggio Emilia) - ITALY  
Via Palladio, 5/A

Tel. +39 0522 622011  
Fax +39 0522 628944

<http://www.aragnet.com>  
[info@aragnet.com](mailto:info@aragnet.com)